

レーザーダイオード用ソケット Laser Diode Socket

丸ピンソケット構造 Round Socket pin type

Specifications (Typical example)
 Dielectric Strength: AC500V RMS 1min
 Insulation Resistance: 500MΩmin
 Contact Resistance: 15mΩ max
 Current rating : 1.0 A
 Operating Temperature: -55℃ ~ +150℃
 (In case of Gold plating Contact)

Material
 Sleeve : Brass, Tin plating over Ni
 Contact : Beryllium, Gold plating over Ni
 Insulator: Teflon PC etc

2.54mm pitch circle

適合リード寸法 Acceptable lead dia. φ0.45/0.0177"

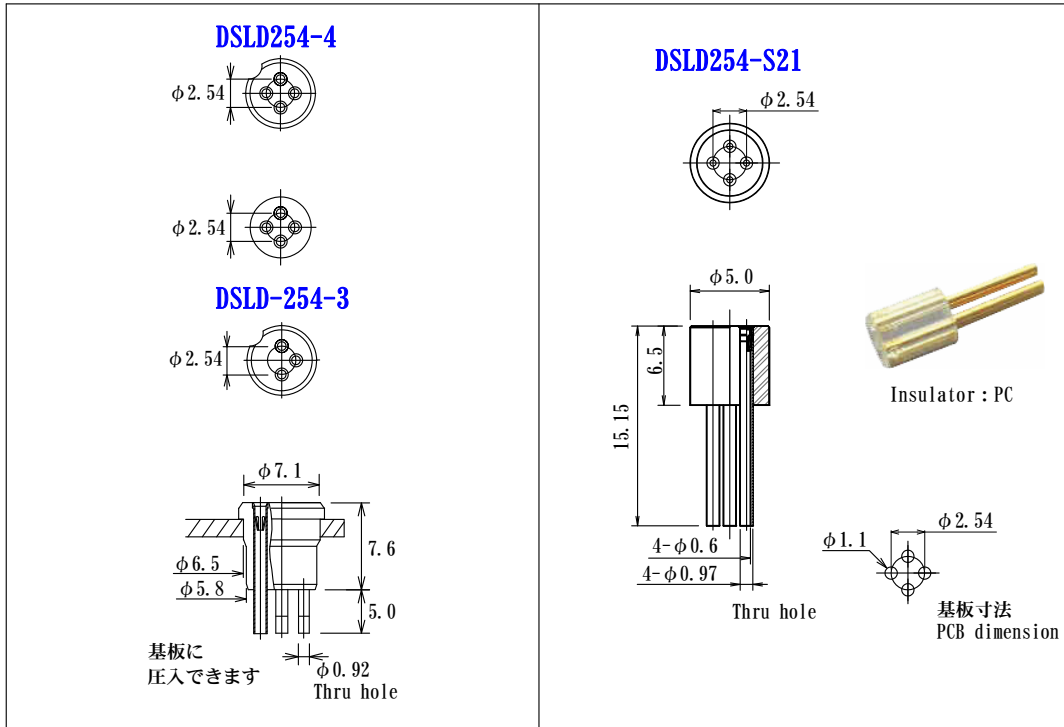

2.0mm pitch circle

適合リード寸法 Acceptable lead dia. φ0.45/0.0177"

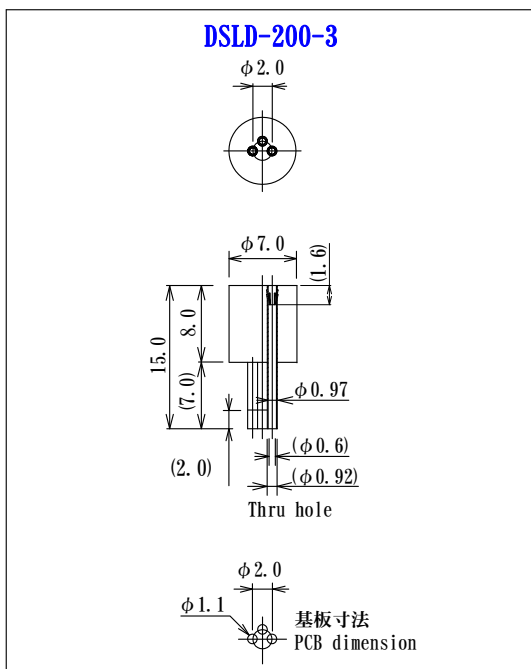

使用ソケットピン (参考)

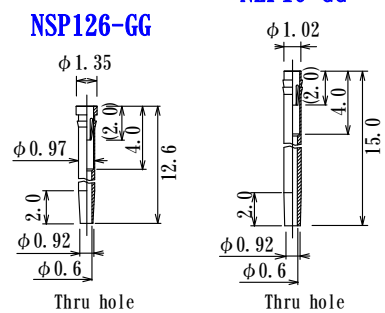

カスタムケーブル付例
Custom order Cable